

Pin the carriage on the Loco

To play the game first cut out and colour in the loco and the four carriages on the following pages.

Fix the loco to the wall, you may want to use some sticky tac, as pins tend to make holes in walls and people.

Now blindfold one of the players and give them one of the carriages, with some sticky tac and see how close they can get to connecting the two.

You could take it in turns to add a carriage each, or let each person in turn build a full train its totally up to you.

Have fun !

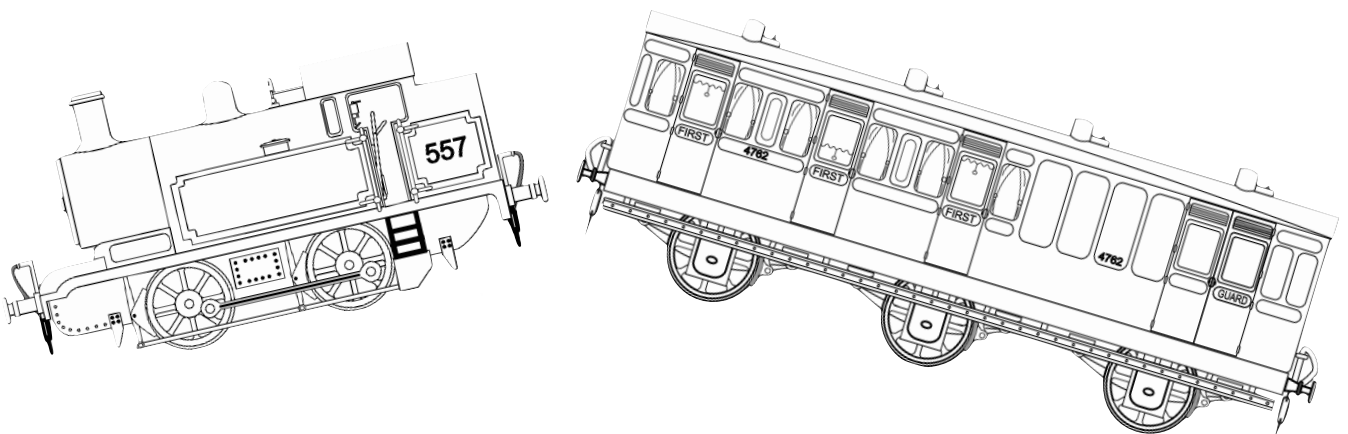
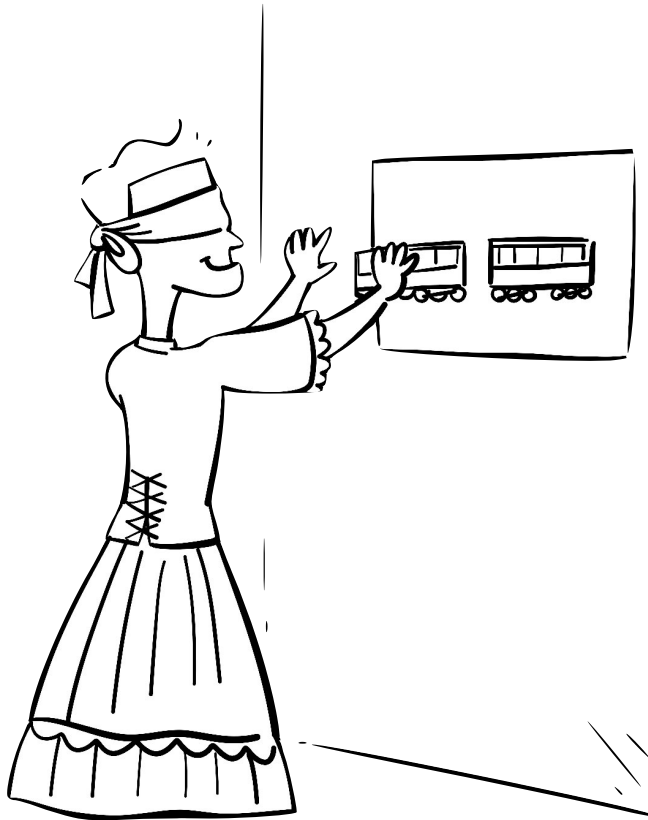

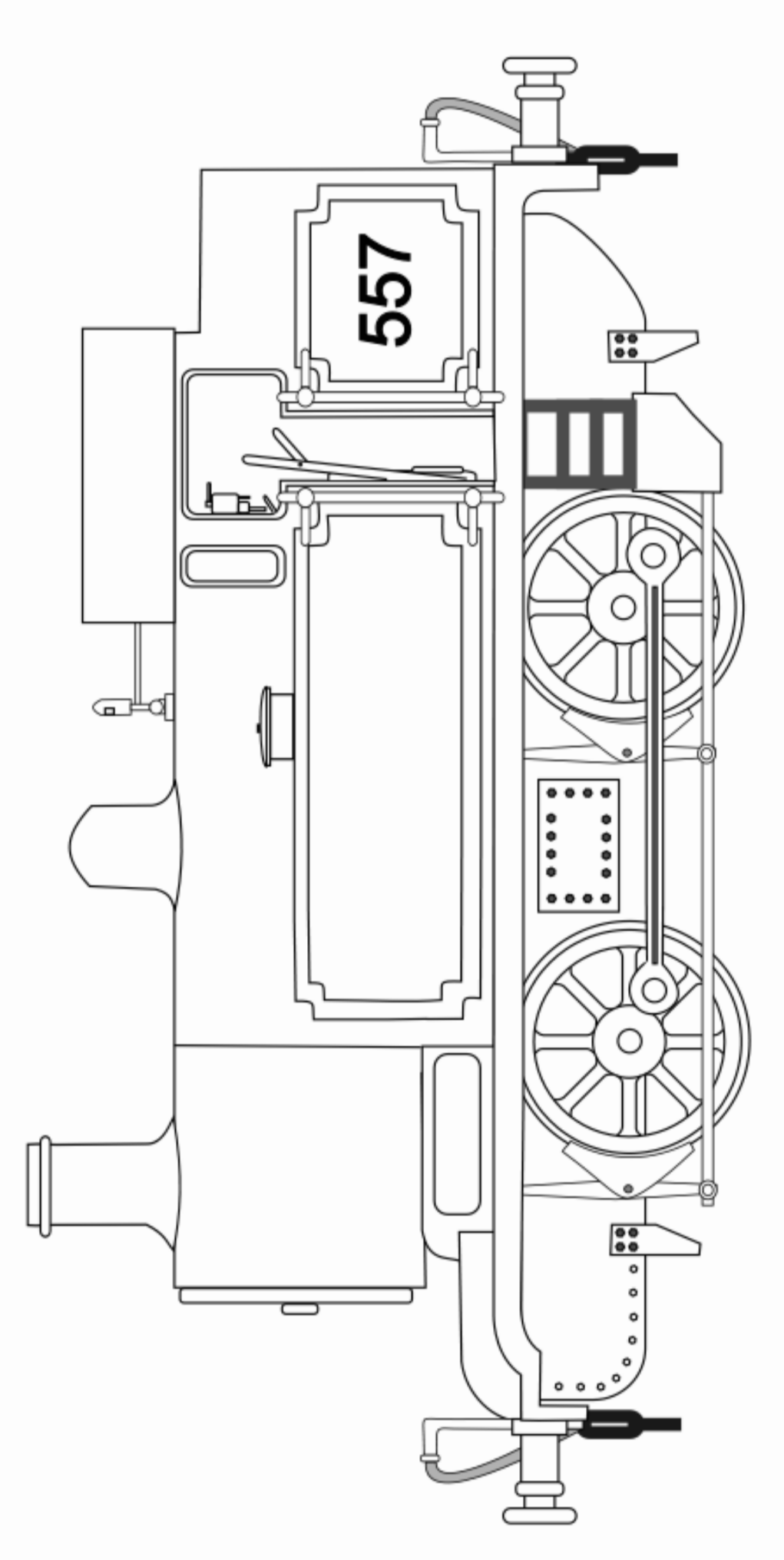

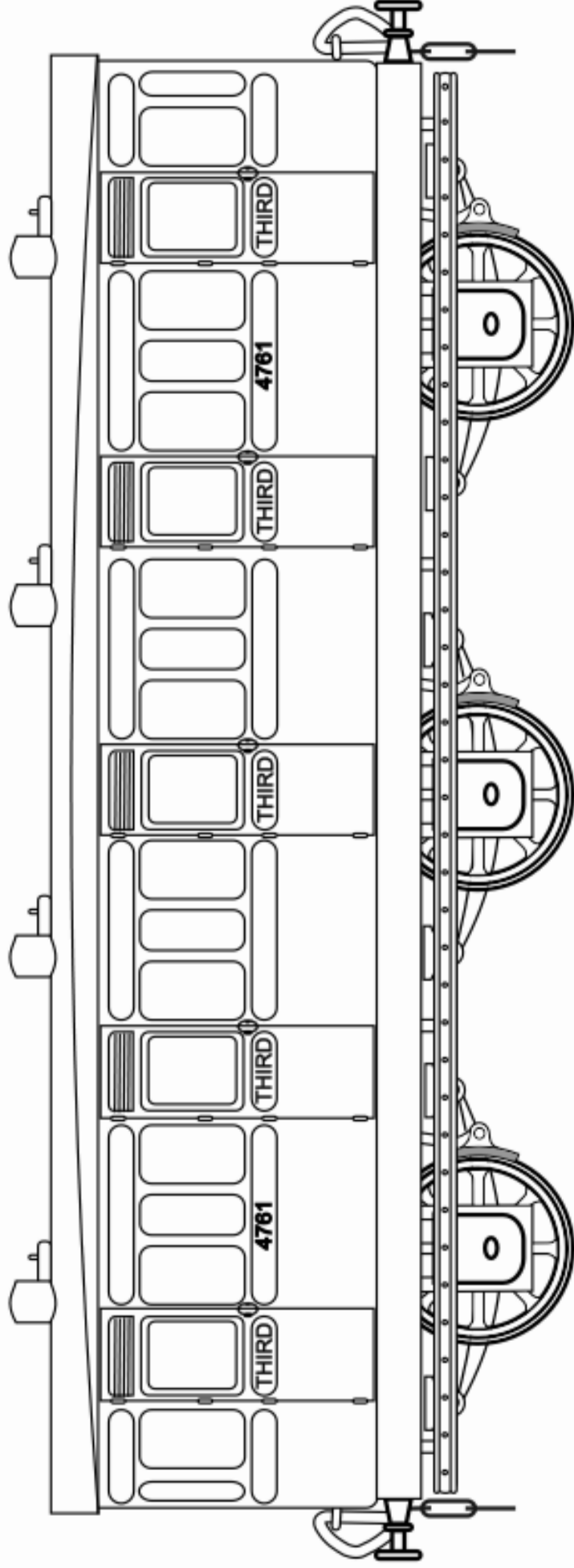

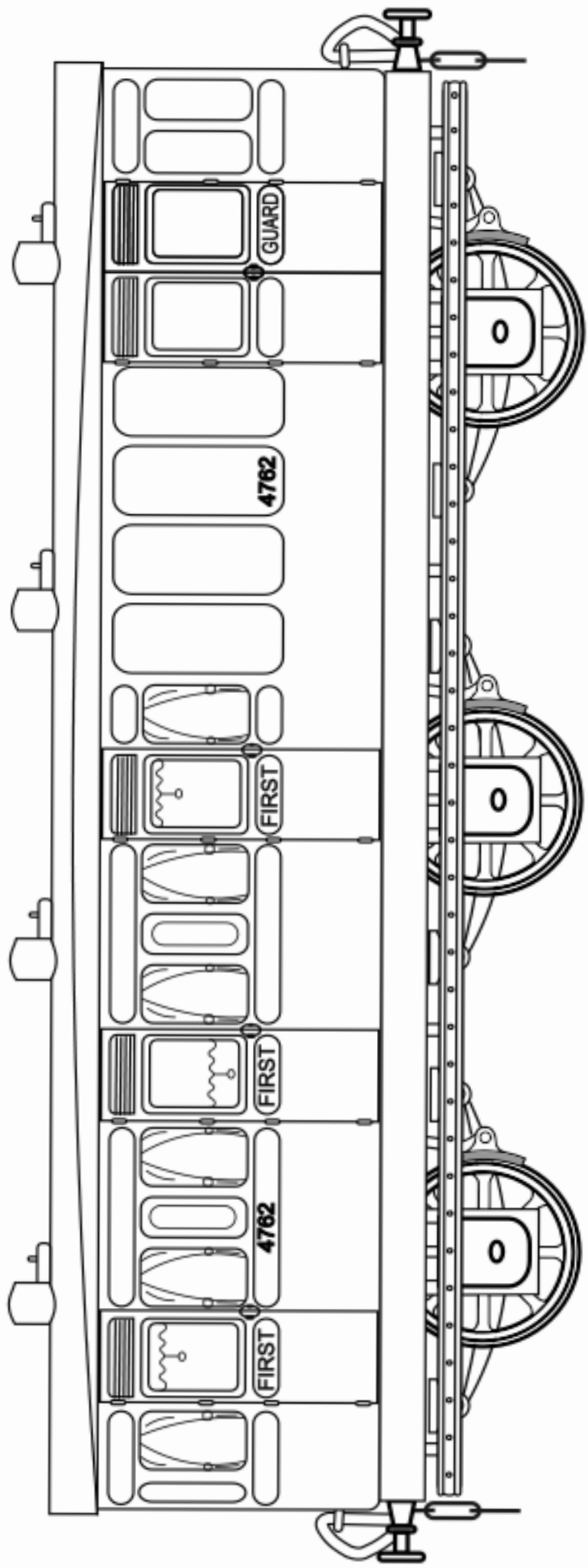

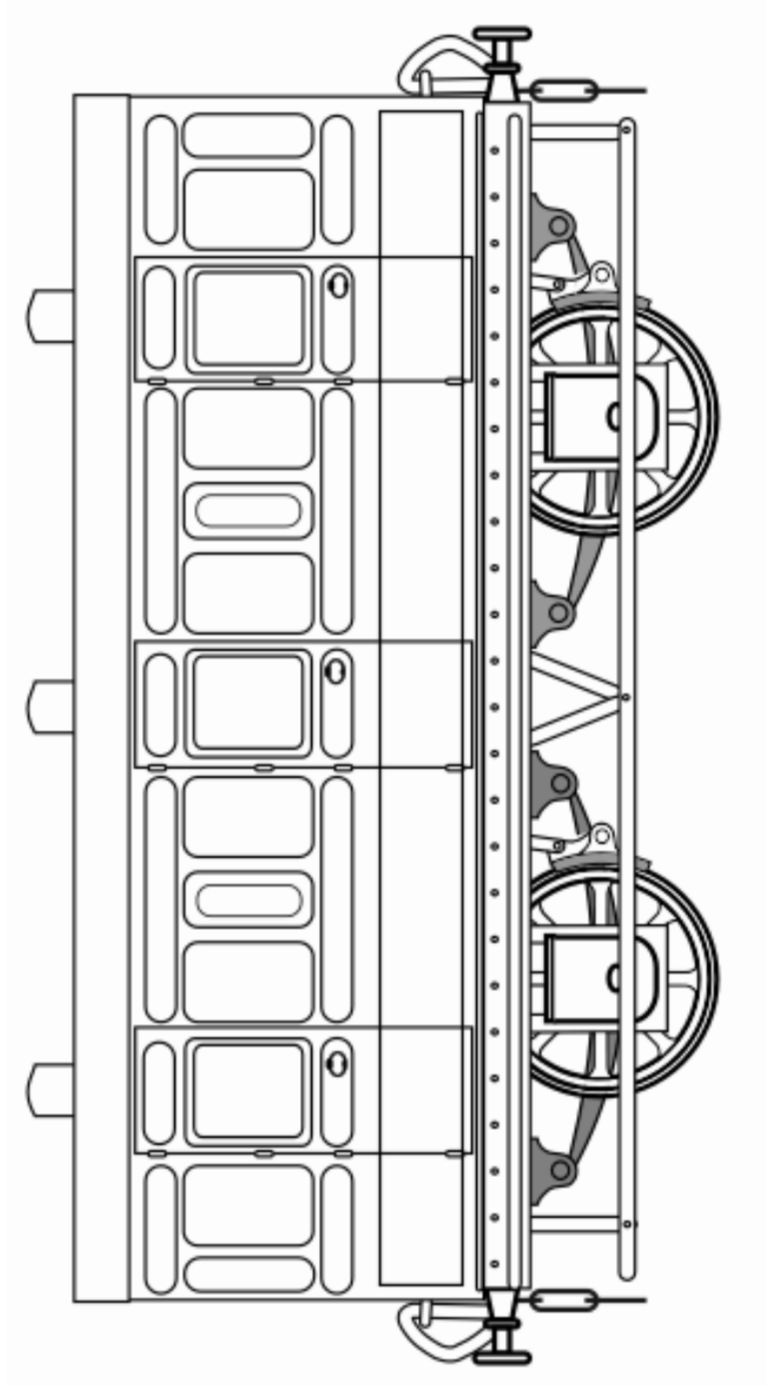

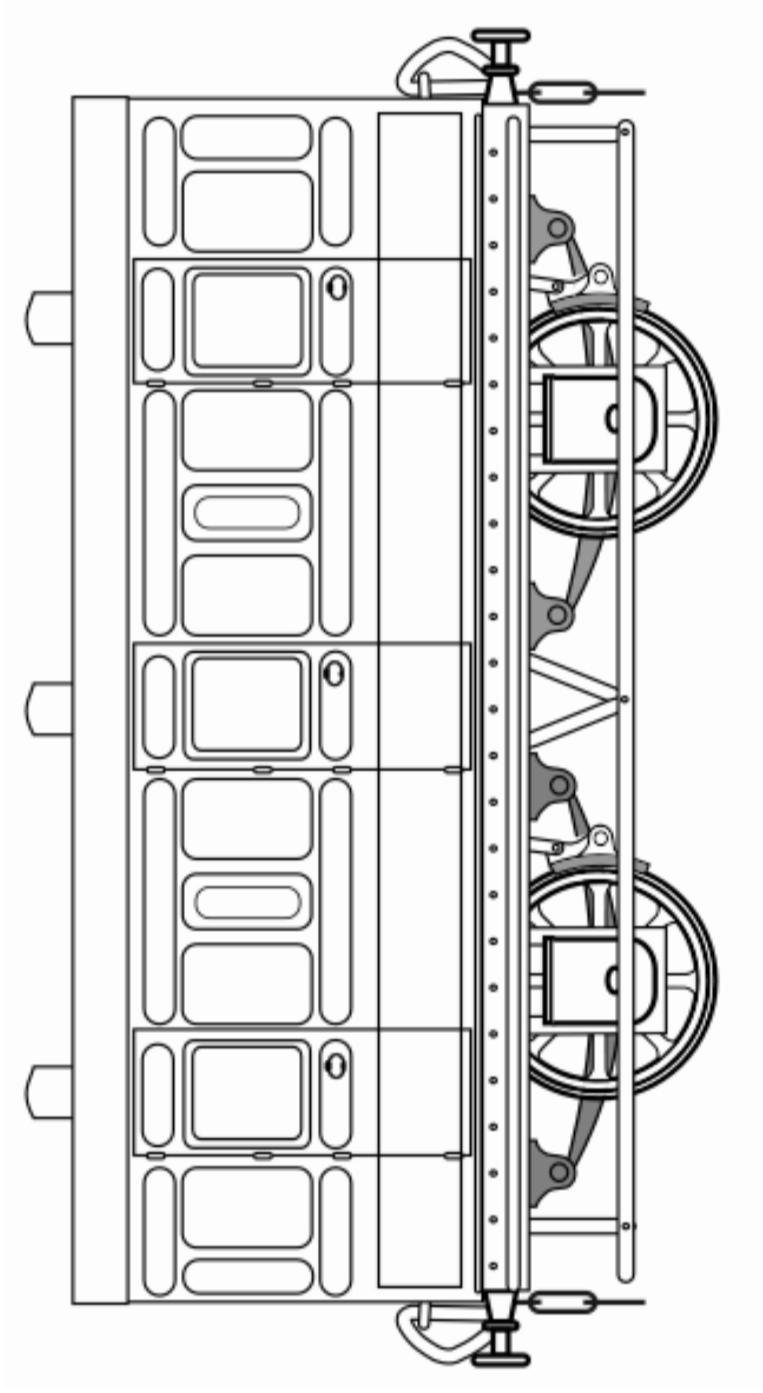

Other books available in the Not-So-Romantic Railways.

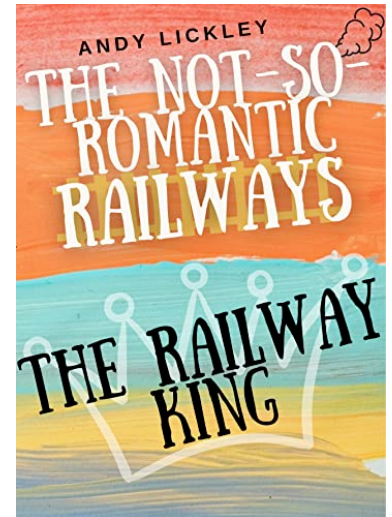
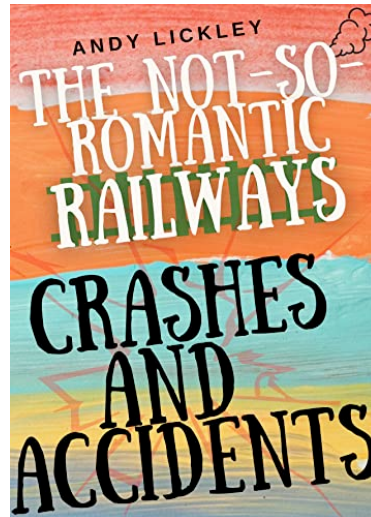
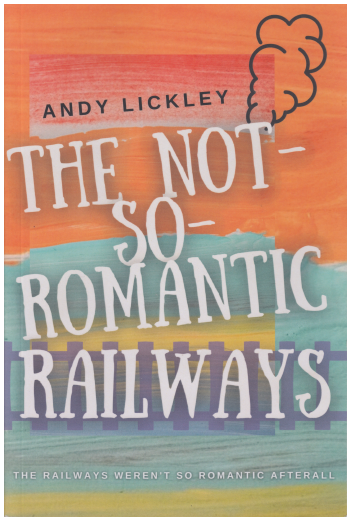

THE NOT-SO-ROMANTIC RAILWAYS

In this book I'm going to take you on a journey through the Victorian Railways to prove that the railways were a lot of things - But romantic wasn't one of them

CRASHES AND ACCIDENTS

This edition of the Not-So-Romantic-Railways takes a look at some of the biggest crashes and accidents that have happened on the steam railways around the world.

THE RAILWAY KING

Tells the story of George Hudson, more commonly known as "the railway King".

All 3 books are available from [amazon.co.uk](https://www.amazon.co.uk) in paperback or kindle edition.

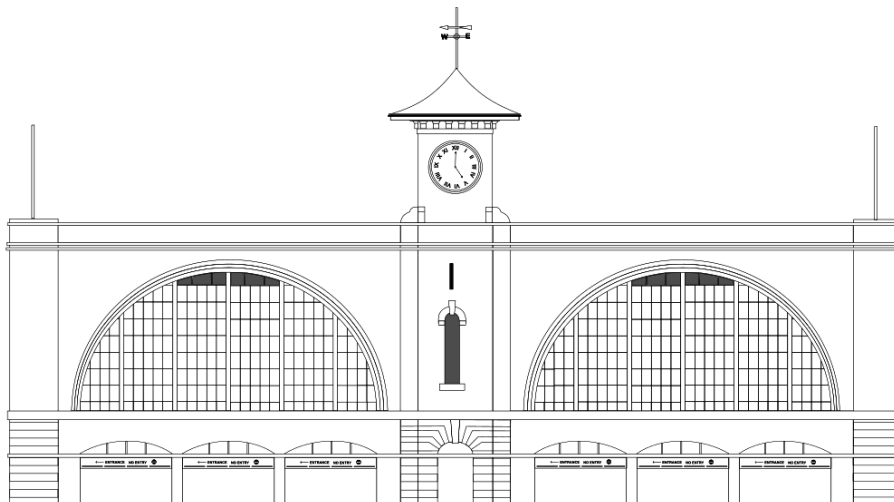

The entrance to London Kings Cross station