

TRACK

If you love snakes and ladders then you'll love tracks and tunnels.

Starting at the bottom station on square 1





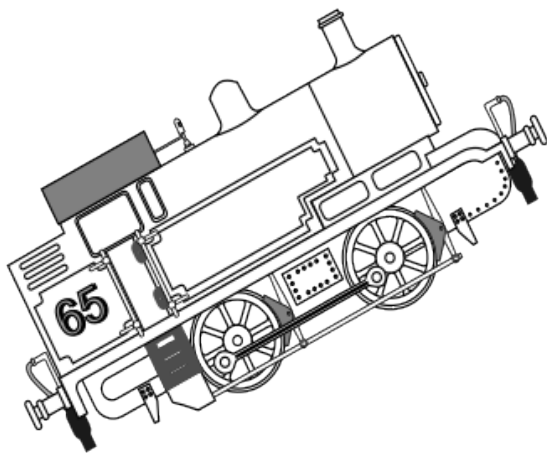













The first player throws the dice and moves their counter to the corresponding place. The next player does the same and all the players take it in turns to throw and move. The winner of the game is the first player to get to the top station on square 100.

Now if a player lands on the bottom end of a track they move UP to the top of that track. Any player landing on the top of a tunnel has to move down to the bottom of that tunnel. If you land anywhere else on a track or tunnel just continue as normal.



100	99	98	97
81	82	83	84
80	79	78	77
61	62	63	64
60	59	58	57
41	42	43	44
40	39	38	37
21	22	23	24
20	19	18	17
1	2	3	4

S AND TUNNELS

 96	95	94	93 	92	91		
85	86	87	88	 89	90		
76	75	74	73	72	71		
65		67	68	69	70		
 56		54	53	 52	51 		
45		 47	48	49	50		
36	35	34		32	31		
25	26	27	28	29	30		
 16	15	14	13	 12	11		
5	6	7	8	9	10		

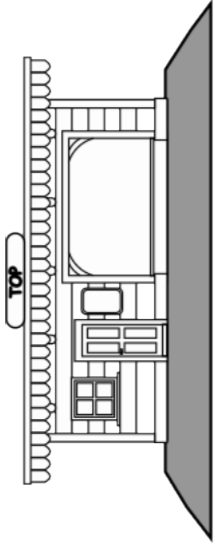

TRACKS AND TUNNELS

If you love snakes and ladders then you'll love tracks and tunnels.

Starting at the bottom station on square 1

The first player throws the dice and moves there counter the corresponding places. The next player does the same and all the players take it in turns to throw and move. The winner of the game is the first player to get to the top station on square 100.

Now if a player lands on the bottom end of a track they move UP to the top of that track. Any player landing on the top of a tunnel has to move down to the bottom of that tunnel. If you land anywhere else on a track or tunnel just continue as normal.

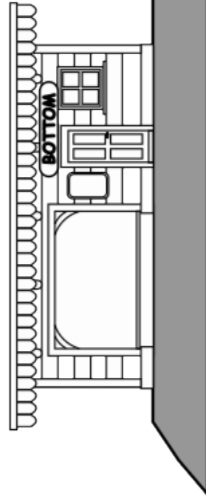
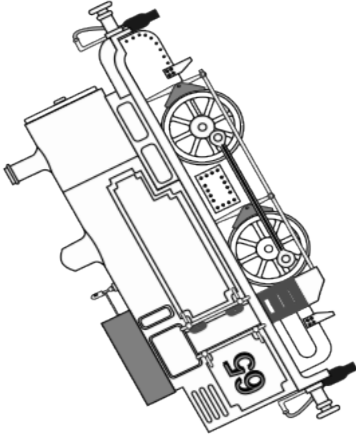

100	99	98	97	96	95	94	93	92	91
81	82	83	84	85	86	87	88	89	90
80	79	78	77	76	75	74	73	72	71
61	62	63	64	65	66	67	68	69	70
60	59	58	57	56	55	54	53	52	51
41	42	43	44	45	46	47	48	49	50
40	39	38	37	36	35	34	33	32	31
21	22	23	24	25	26	27	28	29	30
20	19	18	17	16	15	14	13	12	11
1	2	3	4	5	6	7	8	9	10

Other books available in the Not-So-Romantic Railways.

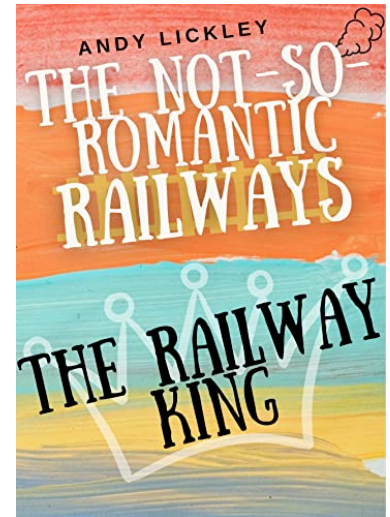
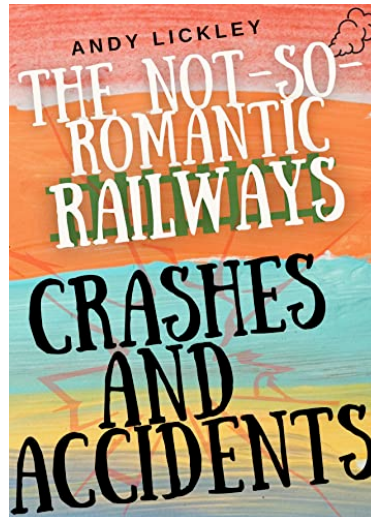
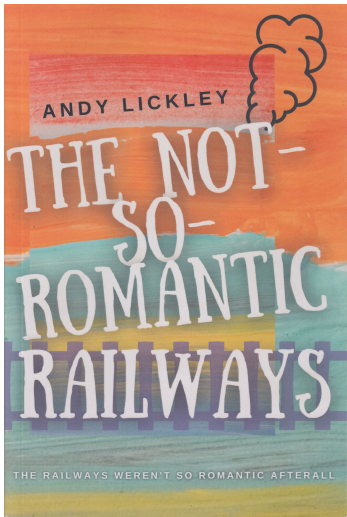

THE NOT-SO-ROMANTIC RAILWAYS

In this book I'm going to take you on a journey through the Victorian Railways to prove that the railways were a lot of things - But romantic wasn't one of them

CRASHES AND ACCIDENTS

This edition of the Not-So-Romantic-Railways takes a look at some of the biggest crashes and accidents that have happened on the steam railways around the world.

THE RAILWAY KING

Tells the story of George Hudson, more commonly known as "the railway King".

All 3 books are available from [amazon.co.uk](https://www.amazon.co.uk) in paperback or kindle edition.

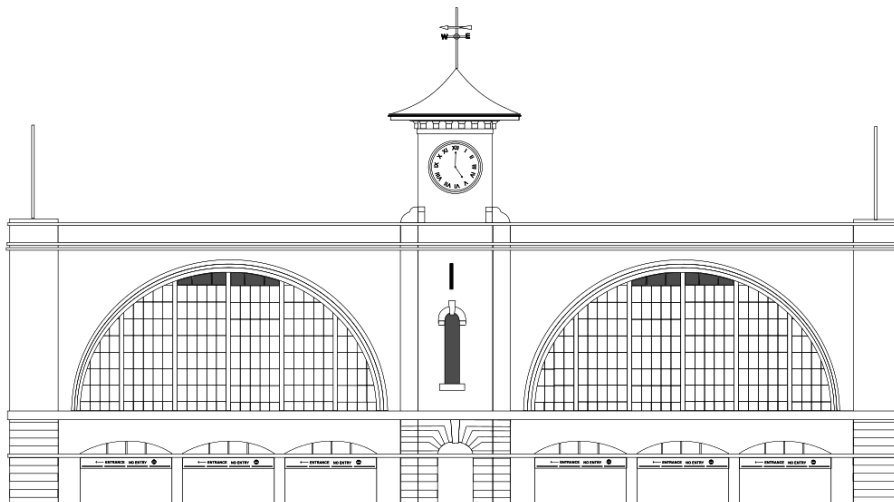

The entrance to London Kings Cross station